



# AARO Suite Speed Sensitive Trip Unit Full Documentation

Software Version 2.00

Don Controls Limited  
Westfield Industrial Estate  
Kirk Lane, Yeadon  
Leeds, LS19 7LX

Telephone: +44 (0)845 1304946  
Fax: +44 (0)845 1304947  
E-Mail: [mail@don.co.uk](mailto:mail@don.co.uk)  
Web: <http://www.don.co.uk>



E104004 (M)



1



180658

## AARO DOCUMENTATION

### CONTENTS

Section 1	AARO	Overview	3 - 5
Section 2	AA4006	Standard Speed Sensitive Trip Unit	6 -11
Section 3	AA4406	Standard Unit + Key Switch and Jack Socket	12
Section 4	AA4106	19" Rack Mount AARO + Modbus Communications	13 - 16
Section 5	AA9000	AARO Signal Generator	17
Section 6	AARO	Sensors and Magnets	18 - 24
Section 8	Don Controls	Contact Names and Numbers	25

## Overview - Speed Sensitive Trip Unit AARO

The AARO control unit is a fully configurable speed sensitive trip unit that monitors the rotational speed of a device via pulses from an input sensor and allows a trip point to be set anywhere between the selected speed range. The unit covers a broad speed range and can be applied to a wide variety of industrial speed monitoring applications for the detection of:-

- Shaft or drum rotation
- Under-speed detection
- Over-speed detection
- Conveyor belt slippage
- Low frequency detection

The AARO is ideally suited to many applications including rotary feeders, screw conveyors, bucket conveyors, in fact any rotating machine or device that is required to be monitored for acceptable speed limits.

The AARO can be supplied in a self contained die cast alloy box of rugged construction, suitable for enclosure mounting or 19" rack mounting with various communication protocols for connection to PLC, DCS or SCADA systems.



<b>AA4006</b>	
Standard Version AARO	
Height	94mm
Width	119mm
Depth	72mm



<b>AA4106</b>	
19" Rack mount AARO	
Height	128mm
Width	40mm
Depth	174mm

The AARO can also be supplied in an IP65 enclosure suitable for ATEX CAT3 Zone 22 installations with options for zener barrier and galvanic isolation.

**AA4506**  
AARO-KJ in IP65  
Enclosure



AARO-KJ fitted in an IP65 enclosure and certified to ATEX Cat 3 Zone 22 environment. The AC supply to the control unit and the field sensor input are pre wired to rail mounted fuses and feed through terminals. The enclosure is also fitted with an "Isolate elsewhere before removing the cover" warning label.

**AA4306**  
Galvanic isolated  
standard unit in IP65  
Enclosure



AARO rotation sensor control unit is housed in a GRP box, comprising:  
IP65 box of approximate dimensions 190h x 280w x 130d. The box is fitted with a removable backplate to enable drilling of cable entries and 1 each of the following:

- 1 - AARO rotation sensor control unit
- 1 - MTL5032 galvanic isolator.
- 1 - MTL5991 24V DC supply for galvanic isolator.
- 1 - Mounting rail complete with earth point.

The galvanic isolator is prewired to the AARO signal input.  
The power supply is parallel wired to the AARO supply.  
The galvanic isolator I.S. connections are arranged to provide 50mm clearance from the nearest internal none I.S. wiring.

All other connections are made direct to the devices.

All cable entries must be segregated from the I.S. cables.

Mains connection to the AARO is either 110 or 240V AC 50HZ. A variety of sensors can be connected to the unit to indicate input speed including solid state, reed, proximity switch or PEC sensors. For appropriate input devices please read the AARO sensors documentation. The trip relay has 2 isolated change-over contacts available for re-transmission and there is also a non-isolated 0 – 10V DC output that can be used for remote speed indication or connection to a PLC.

Trip delay mode and speed range settings are configured from 4 dip switches (SW1 to SW4) located inside the AA4006 or on the component board for the AA4106.

A screwdriver adjustable potentiometer mounted on the front of the unit is used to set the configured trip mode time delay from 0 to 30 seconds.

The adjustment dial on the front of the unit is used to set the trip point for the configured speed range and enables the controller to span the full speed range therefore allowing the trip point sensitivity to be customized to the application i.e. under-speed, over-speed , coarse or fine trip points.

The 16 LED's located on the front of the unit indicate the speed of the rotating device relative to the trip speed making the required trip setting easy to establish.

There are also LED's on the front of the unit to indicate:

Supply On- Mains supply healthy  
Relay On- Trip relay energised  
Timer - Trip timer delay active  
Input - Input sensor

## AA4006 - Standard Speed Sensitive Trip Unit (AARO)



### Installation

The standard AARO control unit is rated at IP62 and should be mounted in a control cabinet or enclosure with access for setting up and adjustment. There is practically no limitation on the distance between the AARO control unit and the rotating device that is to be monitored and therefore the control unit can be mounted in a remote location in a clean and safe environment.

The case dimensions are 94mm high x 119mm wide x 72 mm deep. Mounting holes are located in the base of the unit and the unit is fixed via 4 off 4mm screws.

### Fixing Details

#### STANDARD ENCLOSURE

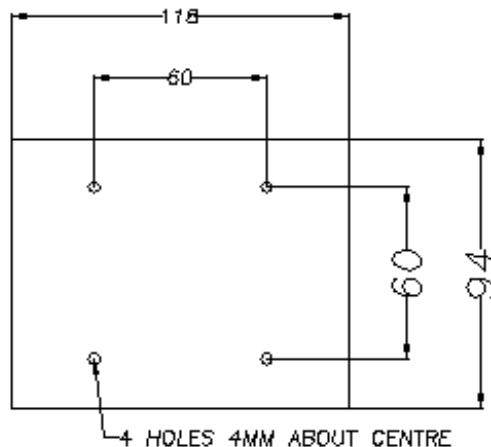

## Electrical connections

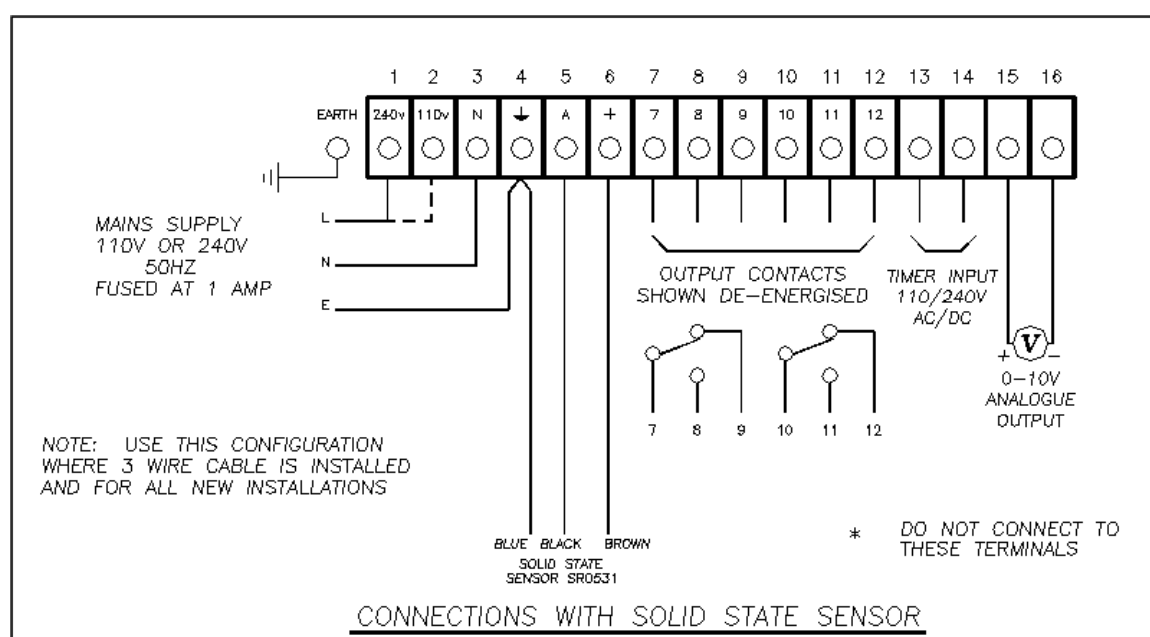
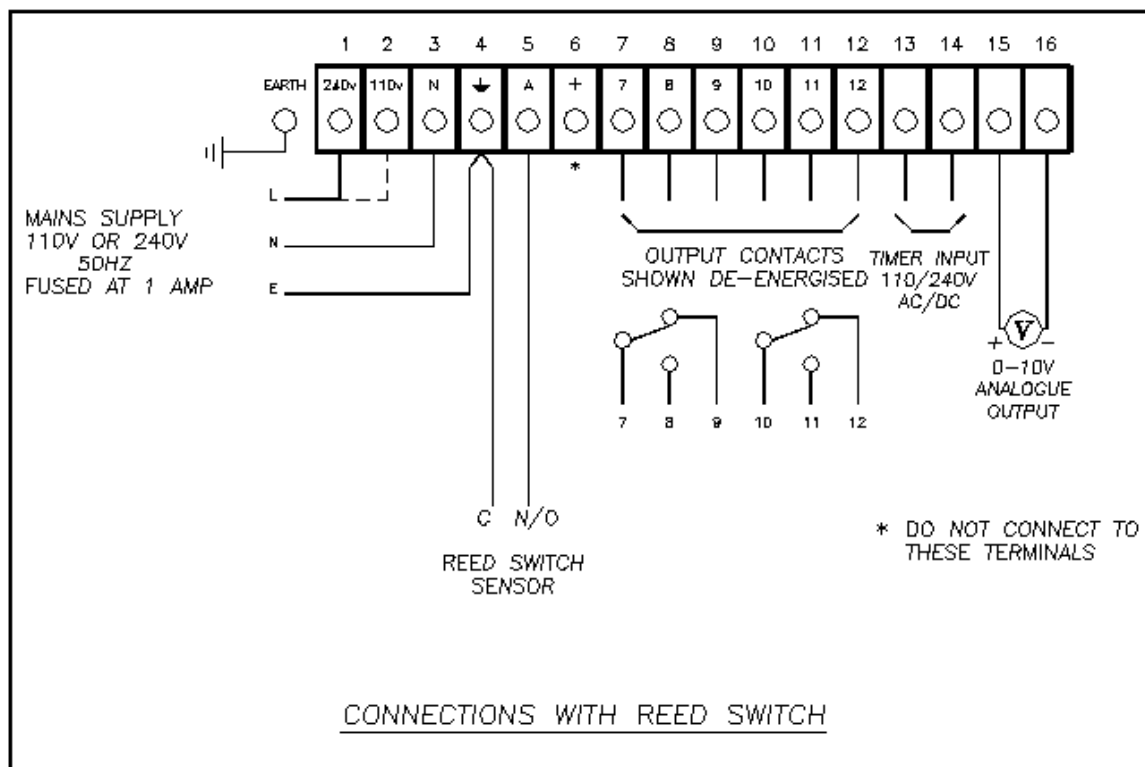

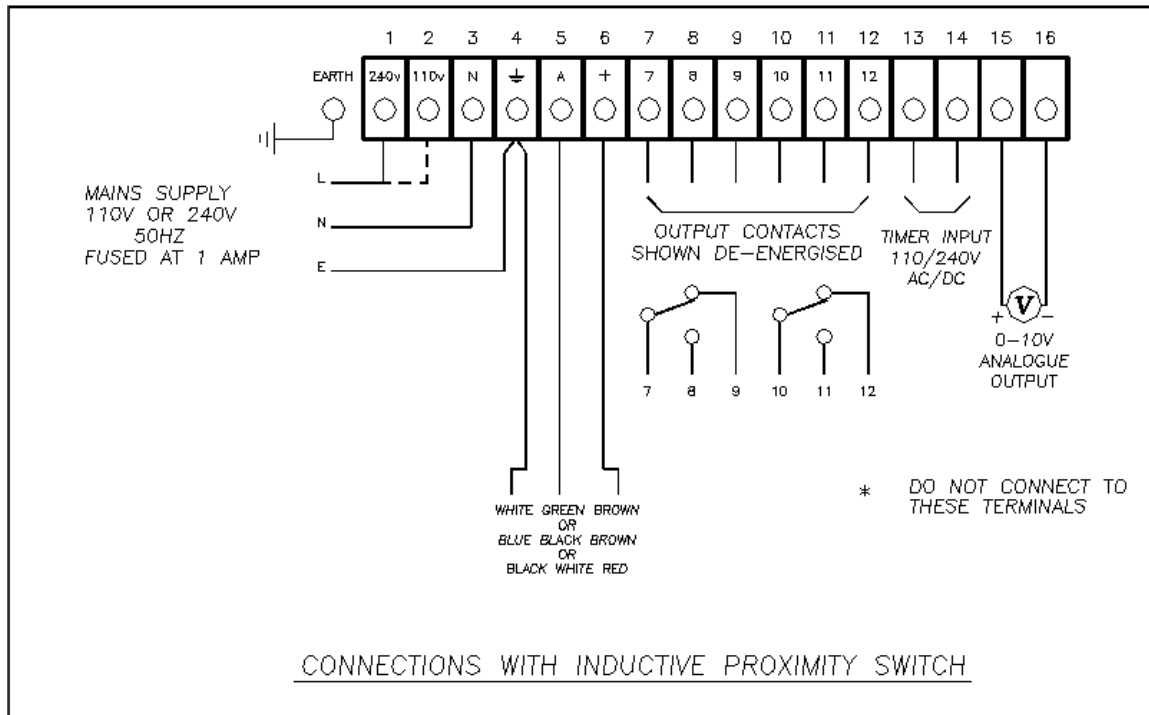

### Wiring Notes:

1. Mains supply must be fused at 1 A
2. Ensure correct connection of mains supply.  
  
110V AC supply - connect **L** to terminal 2, **N** to terminal 3 and **E** to terminal 4.  
240V AC supply - connect **L** to terminal 1, **N** to terminal 3 and **E** to terminal 4.
3. Ensure the unit is correctly grounded. Earthing is an important safety procedure when installing the AARO and also assists in reducing the effects of electromagnetic interference (EMI) on solid state systems such as this unit.
4. Sensor supply for inductive proximity and solid state switches on terminal 6 is +12VDC
5. Sensor switching threshold for inductive proximity and solid state switches on terminal 5 is +6VDC
6. When the AARO is configured for a solid state or proximity switch sensor and an alternative sensor is used to our standard SR0531 or SR0422 then the current drawn by the selected sensor must not exceed 15mA, otherwise overloading of the AARO transformer could occur.
7. Relay contacts – 2 pole change over contacts – 2A @ 250V AC

Common	7	10
N/O	8	11
N/C	9	12



## Configuration settings

Settings are made via 4 off dip switches (1 to 4) located on the underside of the front cover. Remove the 4 corner retaining screws and turn over the top cover. Identify the dip switch block.

Dip switch 1 and 2 select the required timer and relay operating mode.

Dip switch 1	Dip switch 2	Timer mode
OFF	OFF	T4
ON	OFF	T5
OFF	ON	T14
ON	ON	T15

### T4 Timer mode

Following power-up, the relay is held in the **de-energised** state regardless of the input speed, for a time period 0 to 30 seconds. Thereafter the relay will remain **de-energised** whilst the input speed is greater than the setpoint.

### T5 Timer mode

Following power-up, the relay is held in the **energised** state regardless of the input speed, for a time period 0 to 30 seconds. Thereafter the relay will remain **energised** whilst the input speed is greater than the setpoint.

### T14 Timer mode

When the timer input is active (signal on terminal 13 & 14), the relay is held in the **de-energised** state regardless of the input speed, for a time period 0 to 30 seconds. Thereafter the relay will remain **de-energised** whilst the input speed is greater than the setpoint.

### T15 Timer mode

When the timer input is active (signal on terminal 13 & 14), the relay is held in the **energised** state regardless of the input speed, for a time period 0 to 30 seconds. Thereafter the relay will remain **energised** whilst the input speed is greater than the setpoint.

## Configuration notes

1. The time delay period of 0 to 30 seconds is common to all timer selections and is set by the screwdriver adjustable potentiometer located on the front face of the AARO marked DELAY.
2. T14 and T15 timer options are enabled (initiated) when a signal is applied to terminal 13 and 14. A signal level greater than 100V ac/dc will enable the timer function and a signal level of less than 20V ac/dc will disable the timer function.

This option can be used with run/stop interlocking on existing equipment.

If the signal is removed and re-applied during the time period then the time period will be re-started

3. Other timing options are available on request and made to special order.

Dip switch 3 and 4 select the required speed range.

Dip switch 3	Dip switch 4	Speed @ 2 Pulses/Rev	Speed @ 1 Pulse/Rev
OFF	OFF	5 to 55 RPM	10 to 110 RPM
ON	OFF	50 to 550 RPM	100 to 1100 RPM
OFF	ON	500 to 2000 RPM	1000 to 4000 RPM
ON	ON	Reserved for future	Reserved for future

## Operational settings

After setting all the switches, re-assemble the unit and check all connections. Check that the supply voltage is within the correct limits and that connections have been made to the correct terminals. Switch on the supply with the rotating device at rest. All of the LED's will be illuminated for approximately 2 seconds; this indicates the unit is in self-test mode. When the test is completed, the LED's will turn off and the left most LED will flash. Check that the relay is energized or de-energised as required determined by the dip switch configuration.

The trip adjustment potentiometer enables the controller to cover the set speed range. Turning the dial clockwise will increase the trip speed. The speed indication LED's show the speed of the rotating device relative to the trip setting. An increase in input speed will cause the LED indication to move to the right, increasing the trip setting will cause the LED indication to move to the left. When the left most LED indicator is flashing then the input speed is less than 2/3 of the trip speed setting. When the right most LED indicator is flashing then the input speed is greater than 2 times that of the trip speed setting.

When the rotating device is running at the correct speed, set the trip potentiometer as follows:

For underspeed detection, turn the trip potentiometer fully clockwise then turn counter clockwise slowly until the unit just trips. Then turn further counter clockwise to give the required amount of trip margin.

For over-speed detection, turn the trip potentiometer fully counter clockwise then turn clockwise slowly until the unit just trips. Then turn further clockwise to give the required amount of trip margin.

If it is not possible to set the trip point then check:

1. The actual rotating speed of the device is within the speed range that has been configured for the AARO
2. The input sensor is connected correctly.
3. The distance between the sensor and the magnet/flag is within tolerance.
4. The sensor switching threshold is within tolerance and the input LED is switching - on the AARO as the magnet/flag passes the sensor.

Note – The input LED is switched OFF when the input sensor switches ON

The input LED will be ON when the input sensor is OFF or disconnected.

Make adjustments to the trip time delay period as required. When the DELAY potentiometer is turned fully clockwise the delay will be set to 30 seconds and when the potentiometer is fully counter clockwise the delay will be 0.

### **Analogue output**

The AARO is equipped with an analogue output. The signal is ranged 0 - 10V DC with the 0V connection on terminal 16 and the +V connection on terminal 15. The signal represents the actual input speed within the range determined by the speed range dip switches SW3 and SW4. For example, with the speed range switches set to 50 to 550 RPM then the analogue output will be 0 Volts at 50 RPM and +10 V at 550 RPM. This value is based upon 2 pulses per revolution. The output is provided for use with an analogue or digital speed indicator or connection to a PLC. A maximum current of 5mA is available from the analogue output terminals. The signal has an accuracy of 5% of full scale at maximum current.

## AA4406 - Standard Unit + Keyswitch and Jack Socket



### Description

The AA4406 has the same specification as the standard Speed Sensitive Trip Unit with the additional test keyswitch and Jack socket facility. This test facility, allows the AARO unit to read a signal (i.e. from the AA9000 - Signal generator (AASG) via the jack socket, whilst ignoring any sensor input via the terminal block.

The `Run` position is with the key is positioned at 9 o'clock (key is removable). The `Test` position is with the key is positioned at 12 o'clock (key cannot be removed).

When the key is turned from the `Run` position to `Test`, the output relay state will not change.

When the key is turned from the `Test` position to `Run`, the AARO Control Unit resumes normal speed sensing operation.

Note: If the `Test` position is selected before the AARO Control Unit is powered up, the relay will always remain de-energised.

## AA4106 - 19" Rack mount ARRO + Modbus Communications



The rack mounted AARO has the same specification as the AA4406 housed in a 19" eurocard rack. It has an optional Modbus communication module for use with distributed control systems and SCADA packages. It also has the capability to incorporate other fieldbus communication protocols such as Profibus and DeviceNet.

### Communications Option

A small daughter board can be fitted to the main circuit board providing a standard MODBUS RTU serial interface. Other options are available to special order.

The Modbus interface utilises RS485 full duplex (4 wire) interface operating at 9600 baud, 8 data bits , 1 stop bit and no parity.

Each unit is addressed through switches on the serial interface board with an address range of 1 to 126. Data is exchanged between the AARO and the host via separate polled messages

### RTU Request Framing

START	ADDRESS	FUNCTION	CRC CHECK	END
T1-T2-T3-T4	1-126	1	XX-XX	T1-T2-T3-T4
Four character time delay	1 Byte	1 = request data all others N/A	2 Byte CRC	Four character time delay

## RTU Response Framing

START	ADDRESS	FUNCTION	DATA LENGTH	BYTE 1
T1-T2-T3-T4	1-126	1 or 129	1 or 8	0-255
Four character time delay	1 Byte	See note 1	See note 1	Input speed low byte
BYTE 2	BYTE 3	BYTE 4	BYTE 5	BYTE 5
0-255	0-255	0-255	0-255	0-255
Input speed high byte	Trip point low byte	Trip point high byte	Range selection	Timer settings In seconds
BYTE 6	BYTE 7	CRC CHECK	END	
0-255	0-255	XX-XX	T1-T2-T3-T4	
Timer mode options	Status flag	2 Byte CRC	Four character time delay	

**Note 1 :** Following a normal poll request the ARRO slave will respond with 8 bytes of data as described in the table above. However, if an error occurs in the requested data the following response will be made. The function byte will contain the original function value (1) + (128) and this value (129) will indicate that an error has occurred. The data length byte will also contain an error code.

ERROR CODE	DESCRIPTION
1	Bad CRC Received
2	Illegal Function Request
3	No Communication with Main Processor
4	Unit failure
5	(Reserved)

Data format of a typical error response.

START	ADDRESS	FUNCTION	LENGTH	CRC	END
T1-T2-T3-T4	1-126	129	1,2,3,4	XX-XX	T1-T2-T3-T4
4 Character time delay	1 byte	Error Detected	Error Code	2 byte CRC	4 Character time delay

Data contained in a normal response to a polled message.

Data Byte	Description		
1	Current Scaled Input Speed – Low Byte		
2	Current Scaled Input Speed – High Byte		
3	Speed Trip Point – Low Byte		
4	Speed Trip Point – High Byte		
5	Setting	Speed @ 2 pulses/Rev	Speed @ 1 pulse/Rev
	0	5 - 55 rpm	10 - 110 rpm
	1	50 - 550 rpm	100 - 1100 rpm
	2	500 - 2000 rpm	1000 - 4000 rpm
	4	Reserved	Reserved
6	Trip timer setting (0 – 30 Seconds)		
7	Timer Mode Options: 0 = T4 Option 1 = T5 Option 2 = T14 Option 4 = T15 Option		
8	Status Bits 0 = Severe Underspeed 1 = Severe Overspeed 2 = Start-up delay timed out 3 = Relay State : 0 = OFF, 1 = ON 4 = Relay LED Indicator : 0 = OFF 1 = ON 5 = Test Mode : 0 = Run, 1 = Test 6 = Unit Disabled by External Signal 7 = Pulses Lost. (No signal at the Input connections)		

The unit address is set by SW2 and SW3 located on the communications option board. Any address between 1 and 126 may be used for multi unit operation.

### Normal Addresses

Addresses 1 – 126 (7Eh) are used in normal addressing modes. The response to the poll meets the RTU format, however, units requesting data can if they wish ignore any parts of the message and they do not need to implement the CRC, if they do then the transmitted data must be the same implementation as Modbus RTU. Each legal poll will cause the TX/RX led to flash green.

## **Reserved Addresses**

Address 0 (normally used by Modbus RTU as a broadcast command) sets the communications interface to a permanent OFF state. The option board effectively goes to sleep and only monitors the address switches to detect a change. In this mode the TX/RX LED will be illuminated steady amber.

Address 127 (7Fh) causes the unit to transmit continuously without being polled. This operates as a communications test mode and is useful when connecting a single AARO-RM to a simple serial communications device. In this mode the transmitted data is identical to that required by the Modbus RTU. The TX/RX LED will flash red during this mode.

## **Self Test**

When the AARO-RM has power first applied it enters a self test mode. Please refer to the setting up instructions for a description of the self test. The communications board will indicate the self test by cycling the TX/RX LED from green to red to amber. The LED will then change to the colour appropriate for the selected addressing mode



## AA9000 - Signal generator (AASG)



- Integrated circuit reliability
- Liquid crystal display
- No batteries required
- Accurate and stable output
- Easy adjustment
- Small, light, hand held
- Covers all industrial speed ranges
- Enables AARO-KJ set up and test without interruptions to plant operation

### Description

The AASG is a self contained, portable, hand held signal source specifically designed to generate speed simulation signals for checking the operation of rotation sensing equipment. A stable oscillator and digital divider network provide output signals which are supplied to the rotation sensing equipment through a flying lead with jack plug. The frequency of the generated signal is displayed directly in RPM on the liquid crystal display. All power for the signal generator is provided by the AARO 2KJ rotation sensor via the connection lead and jack plug. An LED indicator proves the power supply, a second LED indicator proves the output signals. The output simulation signals can be selected to give 1 or 2 pulses per revolution to suit different applications of the rotation sensing equipment.

### Specification

Speed ranges	:	1.000 – 9.990 rpm	:	10.00 – 99.90 rpm
	:	1.000 – 9.990 rpm	:	10.00 – 99.90 rpm
Resolution	:	0.1%		
Accuracy	:	0.1% of reading		
Output	:	Open collector to suit AARO		
Response Time	:	150ms (max) for correct speed display		
Dimensions	:	112mm x 61mm x 43mm		
Weight	:	300 grams approx.		

## Sensors

### SR0421 – Reed Switch Sensor

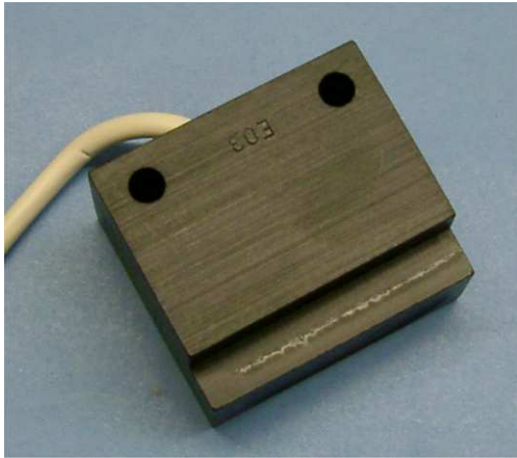

#### Description

The SR0421 reed switch sensor is encapsulated into a rugged weather proof Black Aluminum housing to IP67. The sensor has a 2 metre flying lead and 20mm conduit entry at the back. This 2 wire sensor works in conjunction with a permanent magnet to provide volt free contact signals to an AARO controller. The normal arrangement is to mount the bipole magnet (type MG0150) on the end of a shaft to be monitored for speed and the sensor on a fixed bracket facing the rotating magnet, separated by a gap of up to 19mm. For each rotation, the sensor generates two electrical impulses to the AARO control unit

#### Specification

Speed Range	:	0-125 rpm
Voltage	:	N/A
Current	:	10mA approx.
Temperature Range	:	-20°C to +85°C
Maximum Sensor Gap	:	19mm
Conduit Entry	:	20mm tapped
Dimensions	:	50mm x 58mm x 31mm
Weight	:	300 grams
Connections to AARO	:	2 metre – 3 core flying lead : (blue to terminal 4) : (brown to terminal 5)
MTBF	:	750 million operations

Note – The SR0421 Reed sensor operational life is subject to the effects of cable length which acts to reduce the electrical life expectancy and follows a logarithmic scale. For high speed applications above 125 rpm we would advise that either the hall effect sensor SR0531 or the inductive sensor SR0422 be used.

## SR0531 – Solid State Sensor



### Description

The SR0531 solid state sensor is encapsulated into a rigged weather proof RED aluminum housing to IP67 and contains a Hall effect magnetic field detector and works in conjunction with a permanent magnet to provide signals of speed to an AARO controller. The sensor has a 2 metre flying lead and 20mm conduit entry at the back. The normal arrangement is to mount the bipole magnet (type MG0150) on the end of a shaft to be monitored for speed and the sensor on a fixed bracket facing the rotating magnet, separated by a gap of up to 19mm. For each rotation, the sensor generates one electrical impulse to the AARO control unit. The sensor has a bi-stable output and can be in either state ON or OFF when the magnet is not detected.

### Specification

Speed Range	:	0-100,000 rpm
Voltage	:	12V dc supplied from AARO Controller
Current	:	10mA approx.
Temperature Range	:	-20°C to +85°C
Maximum Sensor Gap	:	19mm
Conduit Entry	:	20mm tapped
Dimensions	:	50mm x 58mm x 31mm
Weight	:	300 grams
Connections to AARO	:	2 metre – 3 core flying lead
	:	(blue to terminal 4)      Blue to terminal 4
	:	(black to terminal 5) OR      Green to terminal 5
	:	(brown to terminal 6)      Red to terminal 6

## SR0422 – Inductive Proximity Switch Sensor



### Description

The SR0422 inductive proximity switch is an M18 short barrel sensor with solid potted internal circuitry to withstand shocks and water washdown to IP67. The thick nickel plated barrel has wrench flats for easy installation and a high visibility LED indicator for sensor operation. The sensor works in conjunction with a rotating flag or bolt head to provide signals of speed to an AARO controller. The normal arrangement is to mount a ferrous flag or bolt head on the end of a rotational shaft or drum and the sensor on a fixed bracket facing the rotating flag. The maximum sensing distance is 5mm. The sensor generates one electrical impulse each time actuation occurs via the rotating flag/bolt head to the AARO control unit

### Specification

Response frequency	:	0.6 K Hz
Voltage	:	12V dc supplied from AARO Controller
Current	:	13mA approx.
Output Configuration	:	NPN – Normally Open Contact
Temperature Range	:	-40°C to +85°C
Maximum Sensor Gap	:	5mm +/- 10%
Circuit Protection	:	reverse connection, surge absorber, load short circuit protection.
Dimensions	:	M18 x 50mm
Weight	:	160 grams
Connections to AARO	:	2 metre – 3 core flying lead (blue to terminal 4) (black to terminal 5) OR (brown to terminal 6)

## Magnets and magnet shrouds

### MG1050 – Magnets



The MG1050 is a powerful permanent magnet 38mm in diameter with a 8mm fixing hole. The magnet can be mounted on the end of a rotating shaft or drum and is used in conjunction with a reed switch sensor (SR0421) or a Solid State Sensor (SR0531).

Note – Permanent magnets are brittle objects and care should be taken when handling, installing or maintaining rotating equipment that are fit with MG1050 magnets.

A plastic magnetic shroud MG1150 is available that not only offers a degree of mechanical protection but also permits easier periodic removal of ferrous particles where there are heavy ferrous dust concentrations.

#### Shaft Mounting

When a single magnet is positioned on the center line of a rotating shaft the sensor will produce 2 pulses per revolution. The maximum flux gap, that is the distance between the sensor and the rotating magnet, should not exceed 19mm.

#### Drum mounting

When 2 magnets diametrically opposed are fitted to a rotating drum the sensor will produce 2 pulses per revolution. The maximum flux gap should not exceed 19mm.

**NOTES ON INSTALLATION OF MAGNET & REED SWITCH  
FOR CAT 3 ZONE 22 APPLICATIONS THE SENSOR WIRING SHOULD BE INSTALLED  
USING FLEXIBLE CONDUIT**

**A. MAGNET MOUNTED ON SHAFT Q ( REED SWITCH GIVES 2 PULSES/REV)**

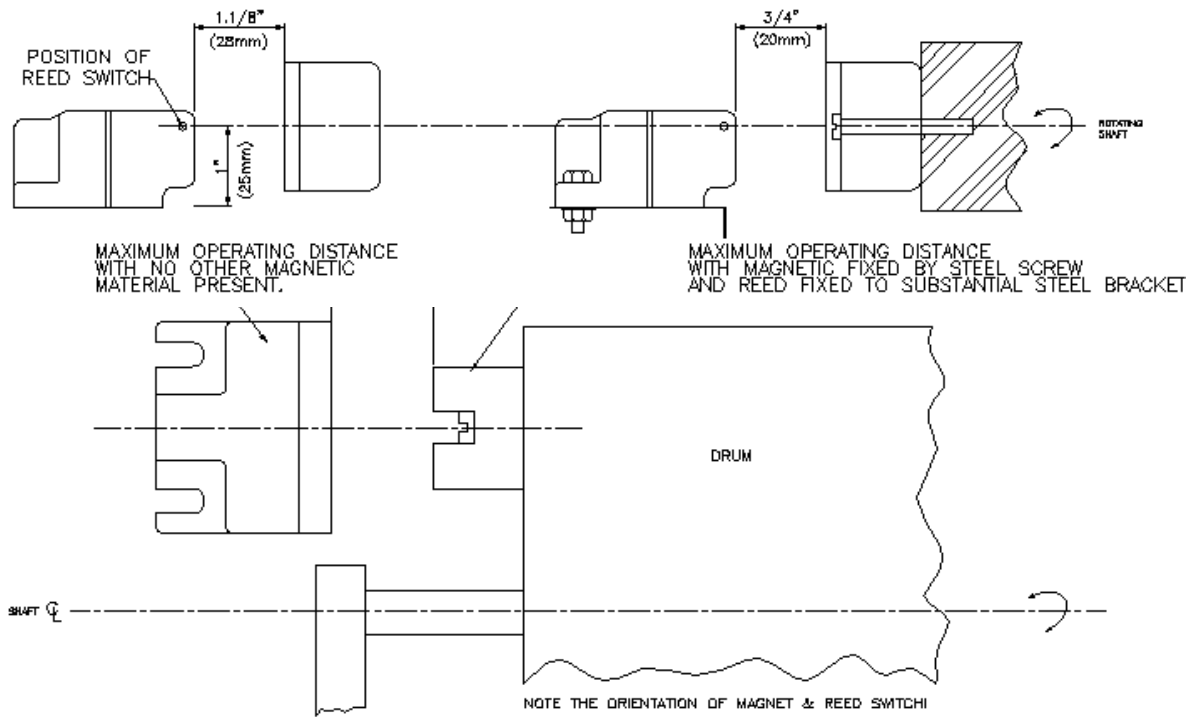

**C. VANE SWITCHING WITH MAGNET AND REED SWITCH STATIONARY  
(FOR SPEEDS LESS THAN 5RPM OR WHEN SHAFT END NOT AVAILABLE)**

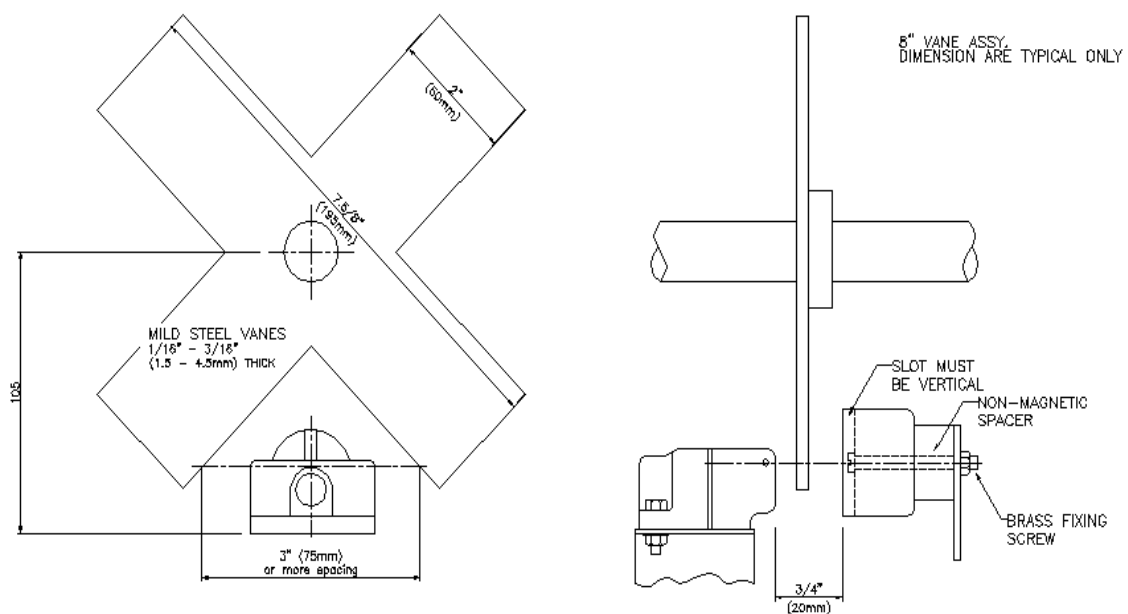

NOTE - MAGNET FIXING SCREW 1/4" DIA. MAX. CHEESE HEAD OR 5/16" DIA. MAX. SOCKET HEAD.

### REED SWITCH SENSOR

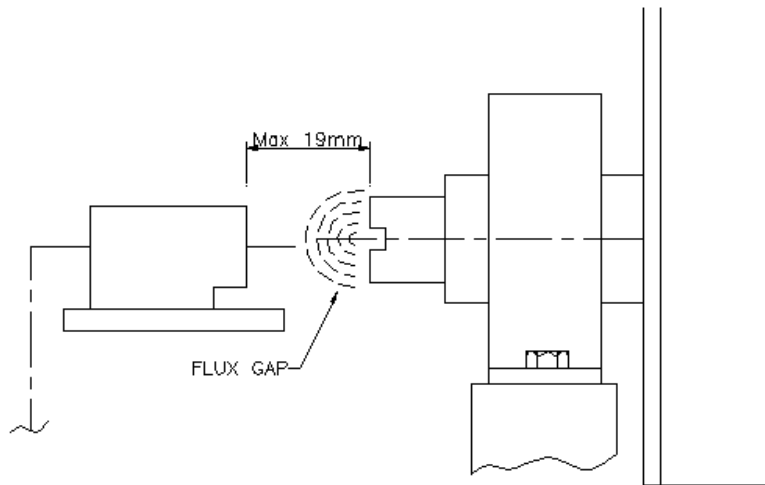

MAGNET FITTED TO ROTATING SHAFT ON CENTRE LINE AND PRODUCES 2 PULSES / REV.

### REED SWITCH SENSOR

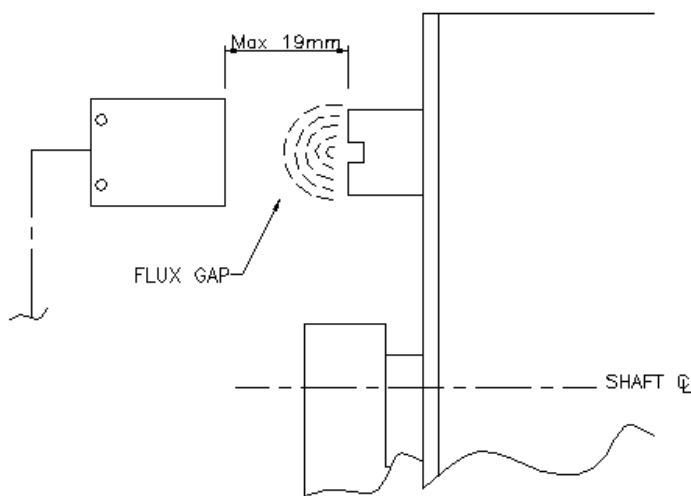

2 MAGNETS FITTED TO ROTATING DRUM  
DIAMETRICALLY OPPOSED PRODUCE 2 PULSES / REV.

## INDUCTIVE PROXIMITY SENSOR

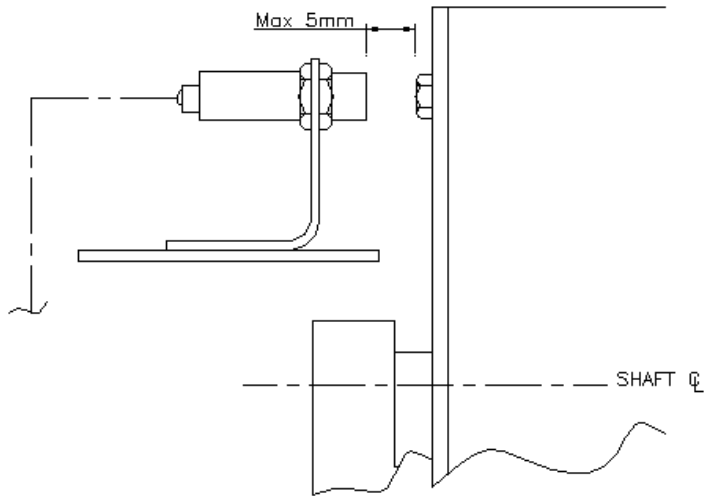

2 BOLT HEADS PROJECTING FROM ROTATING DRUM  
DIAMETRICALLY OPPOSED PRODUCE 2 PULES / REV

## SR0421 Reed switch Sensor and SR0531 solid state sensor dimensions

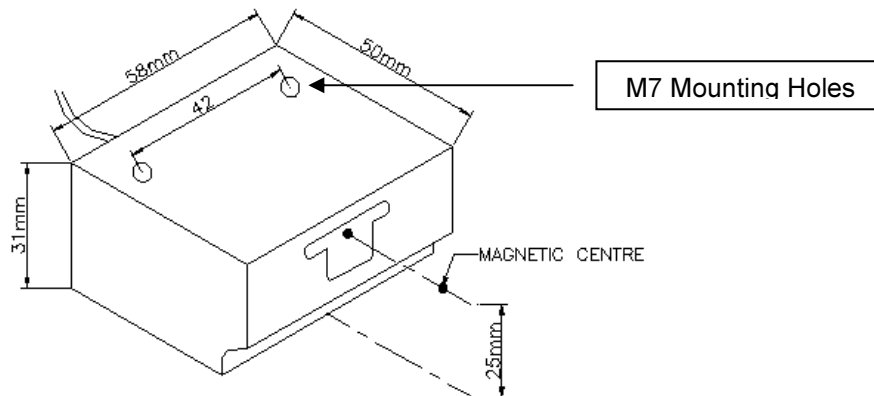



## Contact Names and Telephone Numbers



Richard Wheat

Managing Director

Don Controls Limited  
Westfield Industrial Estate  
Kirk Lane, Yeadon  
Leeds, LS19 7LX

Telephone: +44 (0)845 1304946

Fax: +44 (0)845 1304947

E-Mail: [richardwheat@don.co.uk](mailto:richardwheat@don.co.uk)

Web: <http://www.don.co.uk>



E104004 (M)



25



180658